

**MINUTES OF MEETING**

*Each person who decides to appeal any decision made by the Board with respect to any matter considered at the meeting is advised that the person may need to ensure that a verbatim record of the proceedings is made, including the testimony and evidence upon which such appeal is to be based.*

**TRAILS  
COMMUNITY DEVELOPMENT DISTRICT**

The regular meeting of the Board of Supervisors of Trails Community Development District was held on **Tuesday, February 14, 2012 at 6:00 p.m.** at the Winchester Ridge Amenity Center, located at 15438 Spotted Stallion Trail, Jacksonville, Florida 32234.

Present and constituting a quorum:

Jan Doan	<b>Board Supervisor, Vice Chairman</b>
James Teagle	<b>Board Supervisor, Assistant Secretary</b>
Kathy Shippey	<b>Board Supervisor, Assistant Secretary</b>
Mark Dearing	<b>Board Supervisor, Assistant Secretary</b>

Also present were:

Melissa Dobbins	<b>District Manager, Rizzetta &amp; Company, Inc.</b>
Wes Haber	<b>District Counsel, Hopping Green &amp; Sams</b>
Brian Parks	<b>Field Manager, ASG</b>

Audience

**FIRST ORDER OF BUSINESS**

**Call to Order**

Mr. Doan called the meeting to order at 6:10 p.m. and read roll call.

**SECOND ORDER OF BUSINESS**

**Consideration of the Minutes of the Board  
of Supervisors' Meeting held on December  
13, 2011**

On a Motion by Ms. Shippey, seconded by Mr. Teagle with all in favor, the Board approved the minutes of the Board of Supervisors' Meeting held on December 13, 2011, for Trails Community Development District.
---

**THIRD ORDER OF BUSINESS**

**Consideration of Accounts Payable  
through December 2011**

On a Motion by Mr. Teagle, seconded by Ms. Shippey with all in favor, the Board ratified the Accounts Payable Expenditures through December 2011 in the amount of \$89,158.21 for Trails Community Development District.

**FOURTH ORDER OF BUSINESS**

**Consideration of Operation and  
Maintenance Expenditures for November  
2011 and December 2011**

On a Motion by Ms. Shippey, seconded by Mr. Teagle with all in favor, the Board ratified the Operation and Maintenance Expenditures for November 2011 in the amount of \$6,604.67 and December 2011 in the amount of \$56,390.39 for Trails Community Development District.

**FIFTH ORDER OF BUSINESS**

**Consideration of ADA Compliance  
Proposals**

Ms. Dobbins reminded the Board of Supervisors that per the ADA Compliance Inspection Report the District had specific items that needed to be in compliance by the deadline of March 15, 2012.

Ms. Dobbins stated that the fitness room was completed and is now in compliance. The playground had an additional ground component installed and is now in compliance. The volleyball court was already in compliance. The pool needs two forms of entry. Ms. Dobbins presented a pool lift proposal from Peninsular Aquatics (exhibit "A") and a handrail proposal from Duda Pools (exhibit "B"), which would be the least expensive options.

Board discussion ensued.

The Board approved the proposal from Duda Pool's for handrails in the amount of \$2,000 and the Peninsular Aquatics pool lift proposal with all additional items not to exceed \$5,485.

On a Motion by Mr. Teagle, seconded by Mr. Dearing with all in favor, the Board approved the proposal from Duda Pool's for handrails in the amount of \$2,000 and the Peninsular Aquatics pool lift proposal with all additional items not to exceed \$5,485 for Trails Community Development District.

**SIXTH ORDER OF BUSINESS**

**Consideration of Selection of Audit Committee and Setting Meeting Date**

The Board decided they will act as the Audit Committee and will set the First Audit Committee meeting date for the next regular meeting date, which will be determined by the Chairman.

On a Motion by Mr. Teagle, seconded by Mr. Dearing with all in favor, the Board selected themselves as the Audit Committee and chose the next regular meeting date, which will be determined by the Chairman as the first Audit Committee meeting for Trails Community Development District.

**SEVENTH ORDER OF BUSINESS**

**Consideration of Resolution 2012-01, Transferring the SJRWMD Permit**

Mr. Haber updated the Board of Supervisors that D.R. Horton has outstanding permits with St. Johns River Water Management District (SJRWMD) and due to the fact that the CDD will be maintaining these improvements the permits need to be transferred to the CDD. Before SJRWMD will start that process they need to have this resolution executed to show acceptance by the CDD.

On a Motion by Mr. Dearing, seconded by Mr. Teagle with all in favor, the Board approved Resolution 2012-01, Approving the Transfer of the SJRWMD Permit to the CDD for Trails Community Development District.

**EIGHTH ORDER OF BUSINESS**

**Staff Reports**

A. District Counsel

Mr. Haber stated that the District has been moving forward with the settlement and that the vast majority of the documents are close to being finalized in creating an SPE. This entity will either sell or build on the land. The finalization of the settlement will most likely result in a change of the board and release of the \$164,000 being held in escrow.

Mr. Haber reviewed that there was a 08/09 contract lien which also needs to be released. He requested the Board of Supervisors to authorize District Counsel to work with the Chairman to release this lien upon payment.

On a Motion by Mr. Dearing, seconded by Mr. Teagle with all in favor, the Board authorized District Counsel to work with the Chairman to release the 08/09 contract lien upon payment for Trails Community Development District.

Mr. Haber noted that regarding the Fiscal Year 2012 assessments, the SPE shows a willingness to pay and would like to enter into a funding agreement. He requests authorization to work with the Chairman to draft an agreement and execute it.

On a Motion by Mr. Dearing, seconded by Mr. Teagle with all in favor, the Board authorized District Counsel to work with the Chairman to draft a funding agreement for the SPE and have executed for Trails Community Development District.

B. District Engineer  
Not present.

C. Amenity Manager  
Mr. Parks updated the Board that the District requested proposals on replacing the A/C unit that was stolen. The District's insurance will pay \$5,684.20 and the District is responsible for the \$5,000 deductible

Mark Duda is finishing the repair job on the pool re-piping, but since the pipes are exposed he has suggested securing a metal box panel over them for protection.

D. District Manager  
Ms. Dobbins noted that the next Board of Supervisors meeting will be held on March 13, 2012 at 2:00 p.m.

#### **NINTH ORDER OF BUSINESS**

#### **Supervisor Requests and Audience Comments**

There were no supervisor comments.

An audience member requested for security cameras to be installed as soon as possible.

TENTH ORDER OF BUSINESS

Adjournment

On a motion by Mr. Teagle, seconded by Ms. Shippey, with all in favor, the Board adjourned the meeting at 6:50 p.m. for Trails Community Development District.

  
Secretary/Assistant Secretary

  
Chairman/Vice Chairman

# Exhibit A

# Peninsular Aquatics

4901 1<sup>st</sup> Avenue North  
St. Petersburg, FL 33710  
Ph: 727-328-SWIM (7946) Fax: 727-551-9101  
CPC 1457007 / CGC 1505066

## Proposal:

### General Scope of work:

Supply and install ADA Handicap Chairs for commercial swimming pools of all sizes and shapes.

- Supply and install SR Smiths Splash series ADA aquatic chair lift with extended reach – \$4,990.00 (includes bonding)  
Supply and install second lift on same pool due to over 300 linear feet around perimeter of pool - \$4,700.00 (includes bonding)
- Supply and install SR Smiths AXS series ADA aquatic chair lift - \$4,399.00 (please note: this chair is set up for skimmer style pools only. This model does not have the capability to reach over a roll out gutter style pool per ADA requirements.)
- Supply and install SR Smiths PAL Portable series ADA aquatic chair lift - \$5,999.00

Please Note: There are many specifics for many different style pools. A majority of commercial swimming pools in the state of Florida are constructed with a "roll out gutter" or also known as a "scum gutter". This adds an additional reach to the chair and its application. Prior to installation of the handicap chairs we will visit the pool and discuss best position and location of installation with on site staff.

There are many different substrates of decking around pools; therefore the installation methods will be different on each pool.

If there is a concrete deck around the pool we propose to cut an approximately 12" by 12" square section from decking. We will re-secure bonding to chair from existing pool. We will excavate area to approximately 12" deep and install rebar at bottom as well as dowel rebar into existing deck. Pour high-strength concrete with chair support centered to opening. Re-finish concrete to match existing pool deck as close as possible.

If there is paver decking around pool we propose to strategically remove pavers in the immediate area. We will secure bonding in area affected to chair. We will excavate area to approximately 12" deep and install rebar at bottom. Pour high-strength concrete with chair support centered to opening. Re-install pavers over concrete area, re-sand pavers and paver joints.

Optional Items:

- Additional battery for any of the aquatic chairs listed above - \$234.50
- Cover for the Splash and AXS series aquatic chairs - \$ 316.50
- Splash and AXS series caddy / dolly for removing and placing of aquatic chair - \$443.50
- Armrests for both the Splash and AXS series chairs sold in pairs- \$356.00

Warranty:

- Peninsular Aquatics shall provide a 1 year workmanship warranty on the installation of the chair.
- A 3 year limited manufactures warranty shall prevail on the chair and parts thereof. The chair must be installed by a certified SR Smith installer; all warranty information must be signed by installer and sent via certified mail to manufacture post installation of chair.

Peninsular Aquatics is a full service pool contractor. We construct new commercial swimming pools as well as perform any remodel / modifications to existing swimming pools. Please call us for a free estimate; we are ready to provide you with the service you deserve!

Please feel free to contact me to discuss this proposal.

Thank You,  
Sean Connerty  
727-271-1395



# Splash! Series

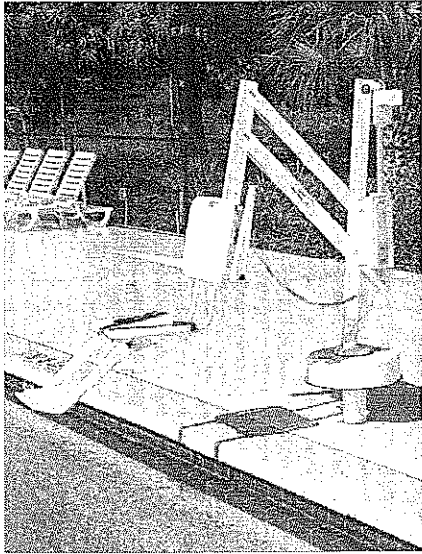

This semi-portable lifting system is designed for swimming facilities seeking to provide user-friendly access to their swimming pools.

- Meets or exceeds Americans with Disabilities Act Access Guidelines (ADA/ABA 2004)
- ◊ 400 pound lifting capacity\*
- ◊ Semi-permanent installation – easily removable from anchor
- Powered by a 24-volt rechargeable battery
- ◊ User operable via waterproof hand control
- ◊ 359° rotation ensures a safe transfer area
- Made from powder-coated stainless steel and aluminum

\*Lifting capacity of the Extended Reach model is 300 pounds

Model No.	Description	Shipping Wt.	L	W	H
300-0000	Splash!	275 lbs.	40"	48"	60"
350-0000	Splash! Hi/Lo	275 lbs.	40"	48"	60"
370-0000	Splash! Extended Reach	325 lbs.	40"	48"	78"
375-0000	Splash! Spa	275 lbs.	40"	48"	60"

Descriptions for other variations:

- ◊ Splash! Hi/Lo – A variation of the Splash! useful for facilities that have both in-ground pools and above ground spas.
- ◊ Splash! Spa – Designed for use with spas up to 48" above the deck.
- ◊ Splash! Extended Reach – For use with pools with unusual gutter configurations requiring a longer reach.
- ◊ Splash! Mariner – Designed to transfer the user from a dock to a boat, it uses a sling instead of a rigid seat, to eliminate physical transfers.

Includes battery, charger, battery console cover, waterproof control, stainless steel anchor socket with cover, footrest and seat belt assembly

## Accessories:

- 400-0000 Caddy
- 170-1000 Arm Rest Assembly
- 940-3000 Total Cover
- 940-1000 Mast Cover
- 500-1000 Spineboard Attachment
- 900-2000 Stability Vest
- 100-1400 Wireless Controls
- 960-1000 Mariner Sling

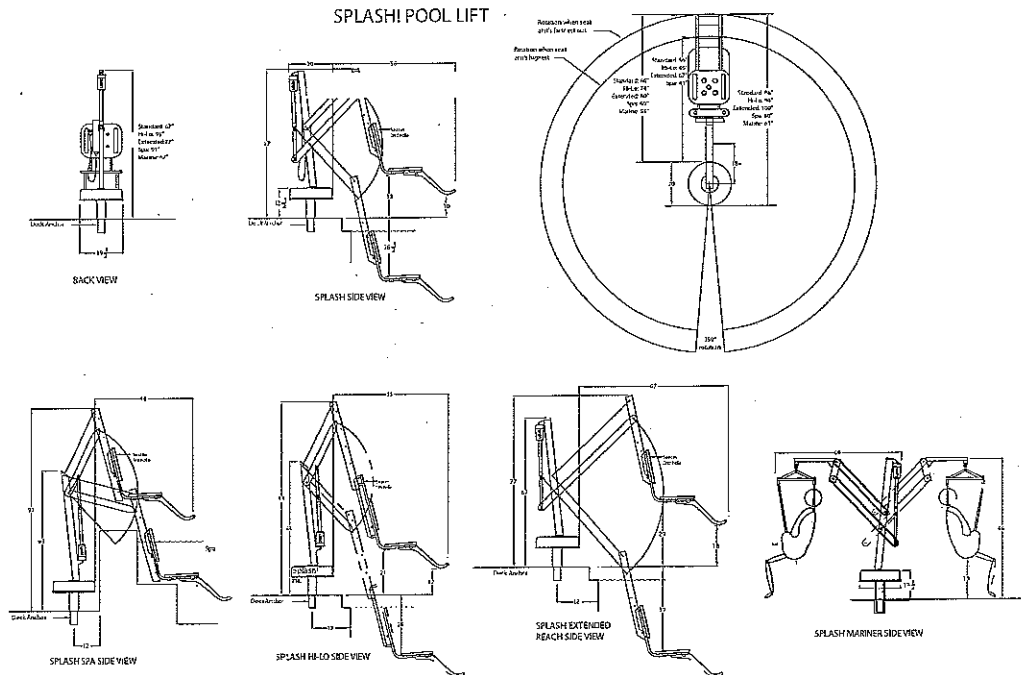

# aXs Lift

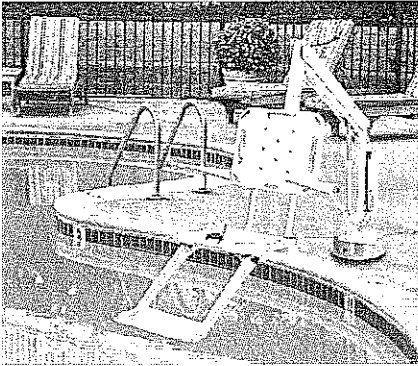

The aXs lift is a perfect accessory for any backyard pool, where its low profile and attractive appearance make swimming pool access easy.

- Meets or exceeds Americans with Disabilities Act Access Guidelines (ADA/ABA 2004)
- ◆ 300 pound lifting capacity
- ◆ Semi-permanent installation – easily removable from anchor
- ◆ Powered by a 24-volt rechargeable battery
- ◆ User operable via waterproof hand control
- ◆ 360° rotation ensures a safe transfer area
- Made from powder coated stainless steel and aluminum

Model No.	Description	Shipping Wt.	L	W	H
AXS1000	aXs	225 lbs.	40"	48"	48"

Includes battery, charger, battery console cover, waterproof control, stainless steel anchor socket with cover, footrest and seat belt assembly

### Accessories:

- AX2320 Arm Rest Assembly
- AX9000 Total Cover
- 500-1000 Spineboard Attachment
- 900-2000 Stability Vest
- 100-1400 Wireless Controls

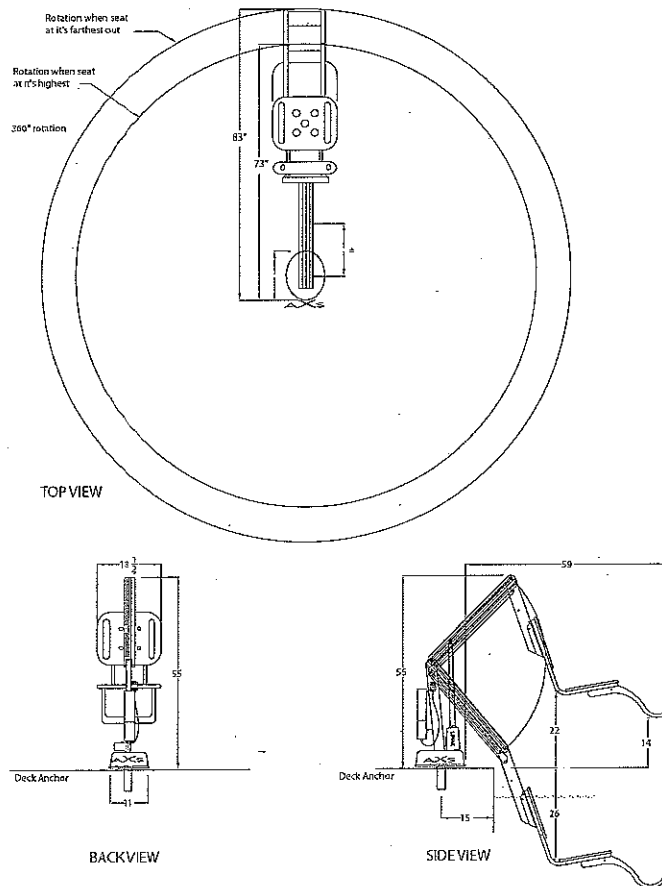

# PAL Series

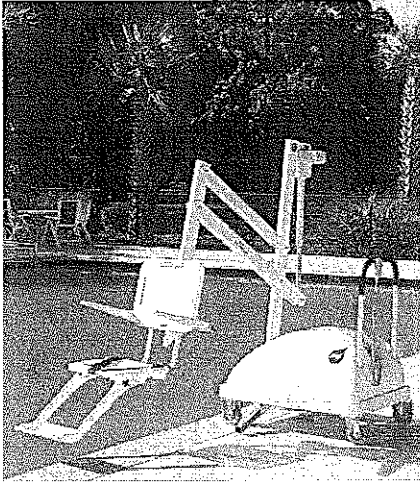

Since its introduction in 1997, the PAL Portable Aquatic Lift has become the industry standard for providing access to swimming pools. The completely portable PAL is the perfect accessory for any commercial aquatic facility.

- Meets or exceeds Americans with Disabilities Act Access Guidelines (ADA/ABA 2004)
- 300 pound lifting capacity
- Completely portable – no deck fixtures and easy to move by one person
- Conveniently stores away when not in use
- Powered by a 24-volt rechargeable battery
- User operable via waterproof hand control
- 240° rotation ensures a safe transfer area
- Made from powder-coated stainless steel and aluminum

Descriptions for other variations:

- PAL Hi/Lo – A variation of the PAL useful for facilities that have both in-ground pools and above ground spas.
- PAL Spa – Designed for above ground pools and spas up to 48" above the pool deck.

Model No.	Description	Shipping Wt.	L	W	H
200-0000	PAL	1,100 lbs.	40"	48"	60"
250-0000	PAL Hi/Lo	1,100 lbs.	40"	48"	60"
275-0000	PAL Spa	1,100 lbs.	40"	48"	60"

Includes battery, charger, battery console cover, waterproof control, footrest and seatbelt assembly

### Accessories:

- 170-1000 Arm Rest Assembly
- 920-2000 Total Cover
- 500-1000 Spineboard Attachment
- 900-2000 Stability Vest
- 100-1400 Wireless Controls

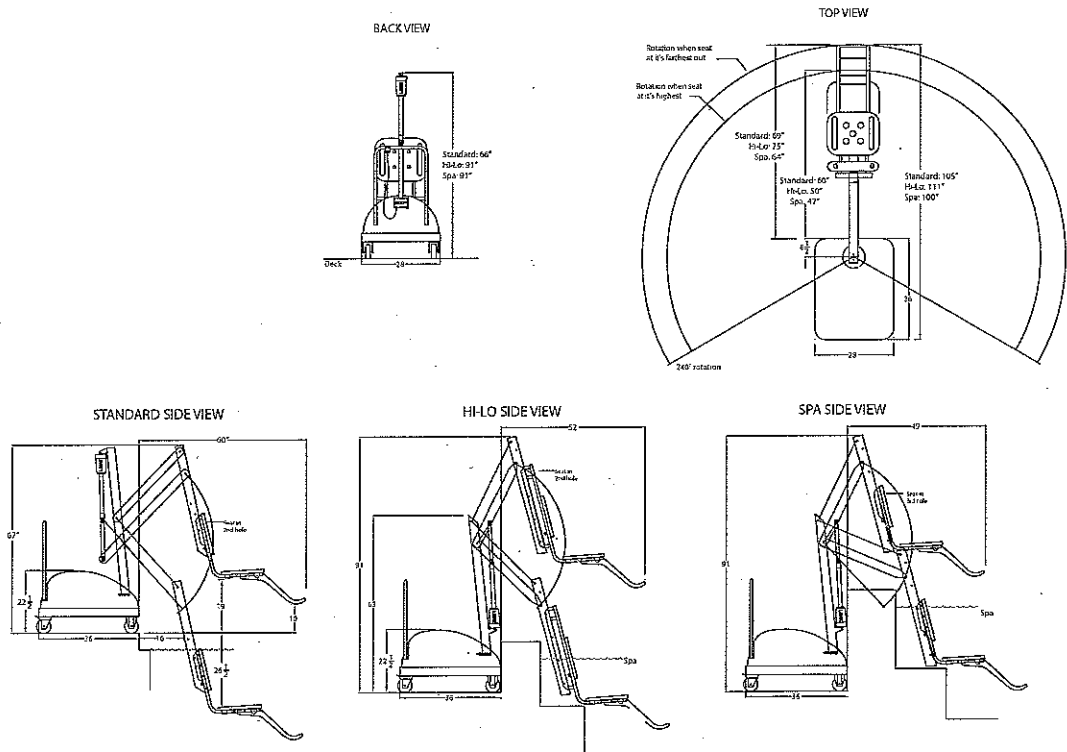

# Exhibit B

**Duda Pools**

2220 CR 210 W  
 Suite 108, pmb 331  
 St. Johns, FL 32259

License # RP252555100

Phone (904) 940-8005

Fax (904) 940-5097

mark@dudapools.com

**Estimate**

Date	Estimate #
2/13/2012	20377

Name / Address
Winchester Ridge 15431 Spotted Stallion Trail Jacksonville, FL 32234

Item	Description	Qty	Rate	Total
Handrail anc...	<p>Installation of two new 7' 3-bend handrails in the FUN pool.</p> <ul style="list-style-type: none"> <li>- Pool will have to be drained below the first step of the pool. *Because of the location of the pool being in a high ground water area, extra precaution will be taken.</li> <li>- Contractor carries 1,000,000/2,000,000 insurance with pop-up coverage.</li> </ul> <p>Anchor will be epoxy gelled into place for long term bond.</p> <ul style="list-style-type: none"> <li>- (2)7' Handrails - 3 Bend</li> <li>- Bonding the new handrail anchor (as required by code)</li> <li>- Marcite the area where the bonding wire is jackhammered out to connect to the other rail.</li> <li>- Install a handrail anchor in the upper deck and in pool</li> <li>- Labor and materials included.</li> </ul> <p>* one year warranty on the anchor not pulling out            ** under extreme circumstances where the handrail is used as a jungle gym, the anchor will weaken and can come out again.</p>	1	2,000.00	2,000.00
			<b>Sales Tax (7.0%)</b>	\$0.00
			<b>Total</b>	<b>\$2,000.00</b>

All work to be completed in a workmanlike manner in accordance with standard practices. Any alterations or deviations from above specifications involving extra costs will be executed only upon written orders and will become an extra charge over and above this estimate. All agreements contingent upon strikes, accidents, or delays beyond our control. Owner to carry fire, flood, and other necessary insurance.

Signature \_\_\_\_\_